

device named after even number is defined to be master or slaver when out of factory and can't changed to the other mode. But for the device named after odd number, users can set the work mode (master or slaver) of the device by AT commands.

HC-06 Specifically includes:

Master device: HC-06-M, M=Master

Slaver device: HC-06-S, S=Slaver

The main function of Bluetooth serial module is replacing the serial port line, such as:

One connects to Bluetooth master device while the other one connect to slaver device. Their connection can be built once the pair is made. This Bluetooth connection is equivalently liked to a serial port line connection including RXD, TXD signals. And they can communicate with each other.

1. When MCU has Bluetooth salve module, it can communicate with Bluetooth adapter of computer and smart phones.
2. The Bluetooth devices in the market mostly are salve devices, such as Bluetooth printer, Bluetooth GPS. So , we can use master module to make pair and communicate with them.
3. Bluetooth serial module's operation doesn't need drive, and can communicate with the other Bluetooth device. But communication between two Bluetooth module require at two conditions:
 - i) The communication must be between master and slave.
 - ii) The password must be correct.

Here are the main factory parameter of HC-05 and HC-06. Pay attention to the difference:

Table 1.1

HC-05	HC-06
Master and Slave mode can be switched	Master and Slave mode can't be switched
Bluetooth Name: HC-05	Bluetooth Name: HC-06
Password: 1234	Password: 1234

2.3. L293D

The L293 and L293D are quadruple high-current half –H drivers. The L293 IS designed to provide bidirectional drive currents of up to 1A at voltage from 4.5V to 36V. The L293D is designed to provide bidirectional drive currents of up to 600-MA at voltages from 4.5V to 36V. Both devices are designed to drive inductive loads such as relays, solenoids, dc and bipolar stepping motors, as well as other high-current/high voltage loads in positive-supply applications.

On the L293D, external high-speed output clamp diodes should be used for inductive transient suppression. A Vcc1 terminal, separate from Vcc2, is provided for the logic inputs to minimize device power dissipation. The L293 and L293D are characterized for operation from 0°C to 70°C.

2.4 DC MOTOR

Almost every mechanical movement that we see around us is accomplished by an electric motor. Electric machines are means of converting energy. Motors take electrical energy and produce mechanical energy. Electric motor is used to power hundreds of devices we use in everyday life. An example of small motor applications includes motors used in automobiles, robot, hand power tools and food blenders. Micro-machines are electric machines with parts the size of red blood cells and find many applications in medicine.

2.5 UART

Universal asynchronous receiver/ transmitter is usually an individual integrated circuit used for serial communications over a computer or peripheral device serial port. UART are now commonly included in microcontrollers. A dual UART combines two UARTS into a single chip. Many modern ICs come with a UART that can also communicate synchronously; these devices are called UART.

3. Block Diagram

A smart phone Android operated robot. Now here is a simple to control your robot/robo car using Bluetooth module HC-06 and 89c2051 microcontroller with your android Smartphone device. The controlling devices of the whole system are a microcontroller. Bluetooth module, DC motors are interfaced to the microcontroller. The data receive by the Bluetooth module from android smart phone is fed as input to the controller. The controller acts accordingly on the DC motor of the robot. The robot in the project can be made to move in all the four directions using the android phone. The direction of the robot is indicators using LED indicators of the Robot system. In achieving the task the controller is loaded with program written using Embedded 'C' Languages. Android smart phone controller Bluetooth robot using microcontroller is shown in figure 1.1.

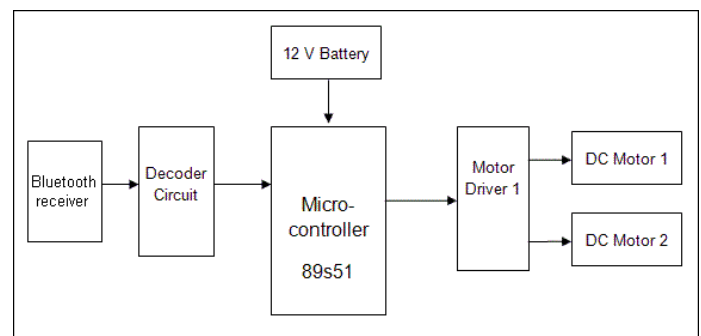

Figure 1.1: Block diagram of android smart phone controller Bluetooth robot using 89s51 microcontroller

4. Application Instructions

4.1 First make sure your HC-06 Bluetooth module is paired with your mobile. The default password for pairing is "1234" or "0000". Check the manual of Bluetooth module.

4.2 Click on “SELECT DEVICE” icon to select paired Bluetooth module.

4.3 When press “up arrow” it sends the data “A” to Bluetooth module connected with the circuit. When microcontroller detects “A” the robot/robot car moves FORWARD.

4.4 When press “DOWN ARROW” it sends the data “B” to Bluetooth module connected with the circuit. When microcontroller detects “B” the robot/robot car moves REVERSE.

4.5 When press “LEFT ARROW” it sends the data “C” to Bluetooth module connected with the circuit. When microcontroller detects “C” the robot/robot car turns LEFT.

4.6 When press “RIGHT ARROW” it sends the data “D” to Bluetooth module connected with the circuit. When microcontroller detects “D” the robot/robot car turns RIGHT.

4.7 When press “STOP” button which is in the centre of remote it sends the data “E” to the Bluetooth module connected with the circuit. When microcontroller detects “E” the robot/robot car gets stopped

4.8 Click on “DISCONNECT” icon to disconnect paired Bluetooth module.

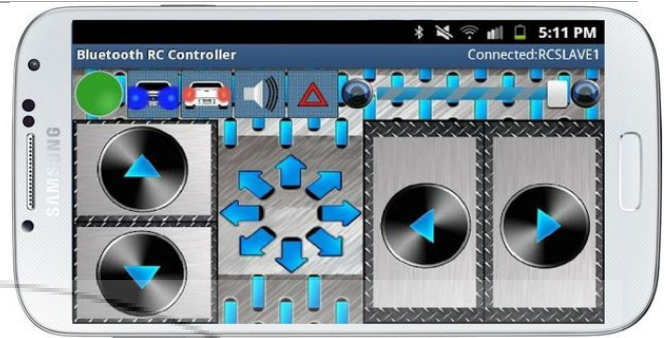

Figure 1.4: to bluetooth connection on to move the robot forward,backward,left and right direction

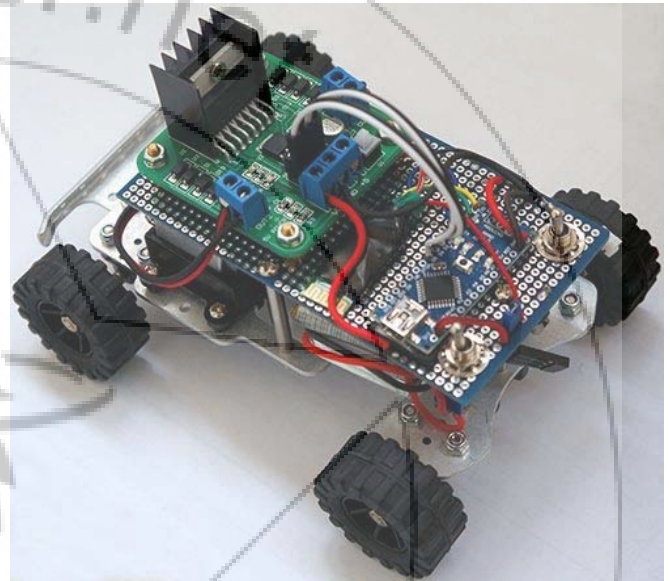

Figure 1.5: Android phone bluetooth controller ROBOT/ROBO

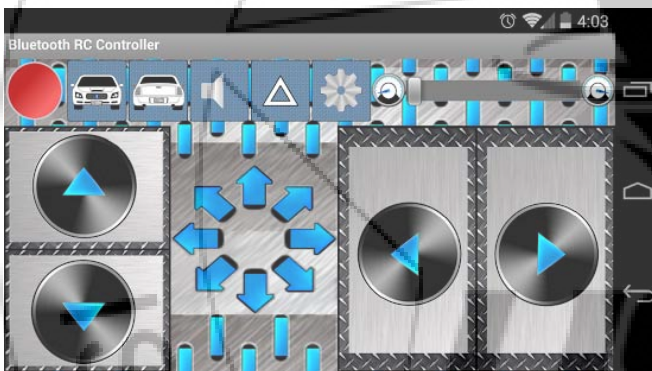

Figure 1.2: arduino bluetooth rc car application

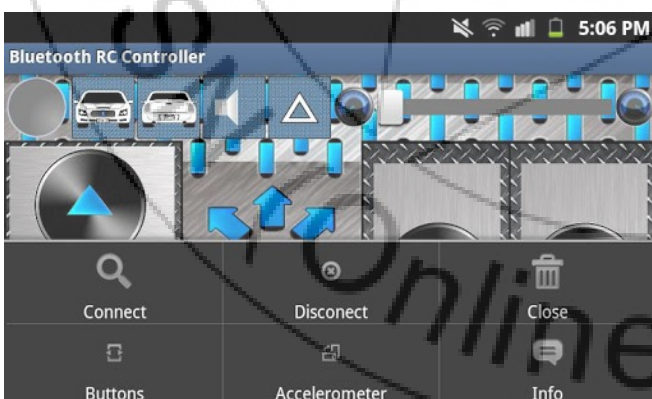

Figure 1.3: bluetooth connection search

5. Conclusion

The objective of the paper is to realise the smart living , more specifically the home lighting control system using Bluetooth Technology. Robot and smartphones are a perfect match, specially mobile robots. As phones and mobile devices are each time more powerful, using them as robot for building robot with advanced feature such as voice recognition. Android bluetooth-enable phones and bluetooth module via HC-06 and communication among bluetooth devices. It is concluded that smart living will gradually turn into areality that consumer can control their home romotely and wirelessly.

6. Future Work

The knowledge is ever expanding and so are the problems which the mankind strive to solve. In this spirit, it is hoped that the current activity will lead to further enhancements. For example; work on future for military purpose by the robot.

Reference

- [1] Android Developers Guide. Android Architecture. [online] 2013. URL: <http://.android.com/about/versions/index.html>.
- [2] Heidi Monson (1999) bluetooth technology and implementations, John Wiley & Sons.
- [3] Piyare, R. and Tazil, M. (2011) “ bluetooth based home automation system using Android phones”. IEEE 15TH International symposium on consumer electronics (ISCE), 14-17 june 2011, Singapore.
- [4] Potts, J. and Sukittanon, S. (2012) “ Exploting bluetooth on android mobile mobile devices for home security application”, proceedings of southeastcan, 15-18 March 2012, orlando, florida,USA.
- [5] HC-06 bluetooth module , http://www.Lanwind.com/files/hc-06_en.pdf.
- [6] Arduino, ios, android and technology tit bits, <http://sree.cc/google/android/using-bluetooth-in-android>.
- [7] Smart phones android operated robot, <http://www.sooxmatechnologies.com>
- [8] Bluetooth based android phone/tablet controlled robot, <http://www.robokits.co.in> and <http://www.robokitsworld.com>