

ENTRUST: A Charity Donation Application Using Concepts of AI / ML

Ayesha Urooj

Department of Computer Science Engineering Department, Osmania University, Hyderabad, Telangana, India

Abstract: *Poverty has worsened, so food inflation has increased, implying that millions of people do not have enough food to eat. The laborious process of managing food and distributing it to recipients, on the other hand, is difficult. Food banks now require a unified management platform that is both efficient and effective. Users can check web applications for their food, clothes, book, etc donations to be verified and processed. The existing procedure takes a long time and demands a lot of effort. There is an obvious need for a system that will allow easy and fast donations and distributions of food to the Ngo's. The researchers of the study will address the problem by developing an online platform for food, clothes, and other goods management services using some AI/ML concepts that would help in the easy segregation of items and gives the organization easy access to the items requested. The project is designed to automate the management of food donors and NGOs. In this paper, we are going to describe a new E-service application. This application will use the concept of image processing at the donor's end. This application follows the Convolutional Neural Network technique in developing the system. The implementation of the system will increase the operational efficiency of necessity reserves in providing food, clothes, books, etc to people who are in need.*

Keywords: NGO, CNN-Convolutional Neural Network, Needy

1.Introduction

This document is a template. India accounts for one-fourth of the global hunger burden, with approximately 195 million underweight people. Because of chronic malnutrition or stunting, nearly 47 million children in India, or four out of every ten, are not reaching their full human potential. Stunting has ramifications such as reduced learning capacity, poor school performance, lower earnings, and an increased risk of chronic diseases. Malnourished girls and women frequently give birth to low-birth-weight infants, which has a multigenerational impact. In India, the prevalence of overweight and obesity in children and adolescents has also increased, with life-long consequences of non-communicable diseases in adulthood.

Donors and non-governmental organizations (NGOs) were mostly small in scale, with small offices located in mosques or churches or occupying a small space within an organization. With rising concern about one's personal beliefs, the charity sector has expanded significantly in recent years. Large charity funding chains sprang up in tandem with the emergence of a diverse range of charity organizations and technology around the world. In a broader social context, innovation is defined as any actual article in our current situation. The emphasis for the motivations behind this venture is on a web way to deal with a good cause in the executives' framework. The World Wide Web utilizes the Internet as a vehicle to convey data, including text, illustrations, recordings, and sound, to anyone with the comparing getting innovation, which today implies a piece of apparatus or equipment and programming known as an internet browser. The Internet allows clients to surf, or investigate, the World Wide Web for data and 6 diversions and has encouraged the development of another plan of action, online business. Internet business is the process of conducting business through contacts made on the World Wide Web.

The government has extensive food security and anti-famine plans, but there are significant gaps in participation and omission failures. Over the last two decades, the government has also taken significant steps to combat under-and malnutrition, such as the introduction of mid-day meals in schools, angina systems to provide rations to pregnant and lactating mothers, and subsidized grain for those living below the poverty line through a public distribution system. The National Food Security Act (NFSA), 2013, aimed to ensure food and nourishment security for the most vulnerable people through its associated projects and programs, making access to food a legal right. So, through this application, we will assist these people in obtaining food.

2.Related Work

[1] This article Developing a Reliable Charitable Donation System During the COVID-19 Epidemic discusses the evolving situation of COVID-19, which has caused a regional disaster. The ultimate goal of their research was to ensure that a blockchain-powered solution would incorporate traditional network technologies. As a service and blockchain technology that accelerates system development and then responds to user needs in a timely manner, the COVID situation has created a high demand for funding and materials. As a system transaction voucher, cryptocurrency can ensure the security of transaction records, personal information and related details. It is designed to control the capital flow process and improve the operational online chain of supporting materials. They also emphasize comprehensive management and processing capacity for material inventory, and we create a charitable donation service system whose framework, technology and operations are constantly evolving. Blockchain is gaining more and more importance in the charitable donation system to share donation information, manage information between donors and beneficiaries, manage contracts between charities and

companies, and its use in processing donations focused on COVID-19 is increasing every day.

[2] Blockchain-Based Material Donation Platform, in this paper, we propose a blockchain-based material donation platform designed and implemented using the Ethereum platform. We solve the difficulty of supplier demand and improve the transparency of the donation process using blockchain; reduce the possibility of another disaster and improve the efficiency of material distribution through smart contracts; and protect the privacy and security of the donation process without information security. We confirm the safety and effectiveness of the proposed epidemic donation platform.

[3] Ek Ka Josh This article is about the idea behind Ek Ka Josh, a program that aims to bring donors and NGOs together. Ek Ka Josh will be a common portal for NGOs and donors. NGOs can upload the causes for which they need support and schedule them. Donors see these causes and pledge amounts up to Rs.1. Thus, Ek Ka Joshi has the potential to bridge the gap between funders and organizations and bring about change in society. This article also analyzes existing systems, user survey, answers to questions from NGOs, tax exemptions, proposed system design and how it aims to improve existing systems.

[4] The paper "Food donation portal" tells us about the development of food donation services and offers an opportunity to connect donors and NGOs. The idea of a food donation network and its effects on society are presented. The disadvantage of this paper is that there is no GPS service to track the donation from the donor to the collector, which means that the system does not allow the institution or the NGO to find the nearest donor who is willing to donate in the area and donors must find them themselves.

[5] Charity Fund Donation Tracking System Based on Blockchain Technology proposed a charity donation tracking system. With blockchain technology, you can make the process of donations and money transactions transparent, and it is applied in various fields. The system proposed in this document provides transparent accounting of donors, charitable funds and recipients of operations based on blockchain technology, allowing public users and donors to track and trace where, when and to whom the funds of charitable funds went. This project is implemented for the Government of the Russian Federation under the theme "Digital Economy of the Russian Federation" on the topic "Development of a Platform for Receiving and Tracking Charitable Donations Using Decentralized Registration Technologies". This work is done using one of the most important technologies-blockchain. The analysis showed that the use of blockchain technology in domestic charities, both individually and at the national level, will not only make donations more efficient and reliable. Ethereum is currently used as a blockchain platform. Smart contracts implemented in Solidity language. The server part was developed using JavaScript on the Node.js platform.

Table 1: Existing Systems

App No.	Application Name	Charity/Donation
1	Food cloud	Food only
2	Waste no food	Food only
3	OLIO	Food only
4	Transfer-Nation	Food only
5	Charity monk	Goods: clothes books
6	e-charity	Money
7	The Roundup	Money
8	Be My Eyes	Volunteering work
9	Go Donate	Food only
10	Coin up	Money

A. Survey

In order to understand the workflow of non-profit organizations we interacted with a few NGO's like

Salama Foundation: This is a social service organization where there are more than 100 refugees from Rohingya, Myanmar, Afghanistan, etc take shelter in this organization; they provide every basic amenity to the people from basic daily needs items to food if needed. So, this organization is in need of many items as we discussed our idea where the organization can ask for anything they want and the willing donor can accept their request and give them what they need. They were open to the idea of registering for it and using it at their convenience.

Setwin Services: This is a government organization where women take up small branches and teach underprivileged women or girls basic courses. As we discussed this idea about Entrust they were excited about it and asked if they could get help in terms of money for any underprivileged girl getting married. So we do have a Ngo dashboard where they can ask donors to help with furniture or any amenities that would help the girl get married.

Millat e madrasa: This foundation has 30 orphans from ages 5 to 15 years these kids needs books, toys, blankets, and clothes too. Our idea of Entrust made them really interested and acknowledges the idea to help the needy in this easy manner.

Fatimabi Old-age home: This old-age home comprises 30 women between the ages of 65-85 years old. The women here are in desperate need of things like hospital supplies, beds, medicine, clothes, proper food, etc. There are many volunteers or donors that will help these kinds of organizations and Entrust can be the gateway to it.

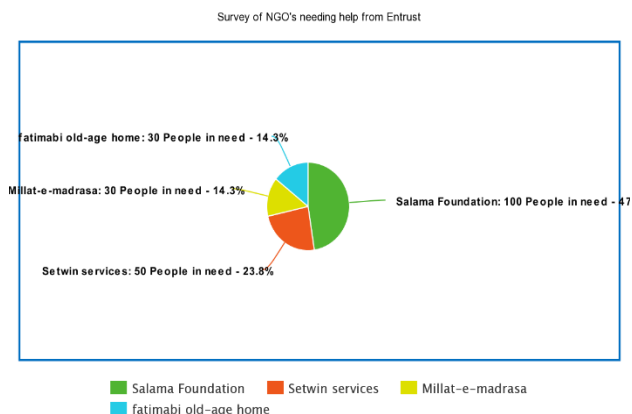

Figure 1: Survey of NGO

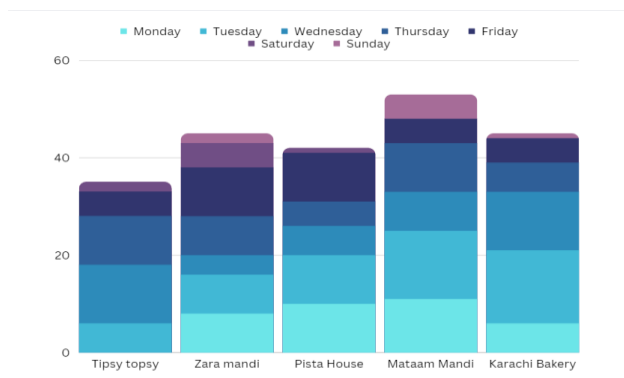

Figure 2: Survey of Restaurants

3. System Design

1. Presentation Layer (UI): The presentation layer contains pages like .aspx or windows form where data is presented to the user or input is taken from the user.

2. Business Access Layer (BAL) or Business Logic Layer: BAL contains business logic, validations, or calculations related to the data if needed.

3. Data Access Layer (DAL): DAL contains methods that help the business layer connect the data and perform the required action, which might be returning data or manipulating data (insert, update, delete, etc.).

A 3-tier architecture because the three important modules like the UI, logic, and database are independent of each other and are clearly defined. Also modifying any one tier will not affect the other. Along with it we get the following benefits from using 3-tier architecture:

Scalability: Each tier can scale horizontally. For example, you can load-balance the Presentation tier among three servers to satisfy more Web requests without adding servers to the Application and Data tiers.

Performance: Because the Presentation tier can cache requests, network utilization is minimized, and the load is reduced on the Application and Data tiers. If needed, you can load-balance any tier.

Availability: If the Application tier server is down and caching is sufficient, the Presentation tier can process Web requests using the cache.

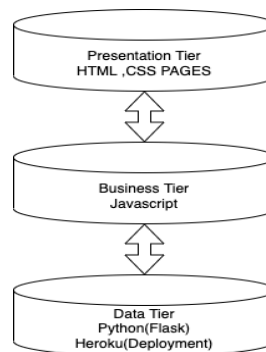

Figure 3: System Architecture

4. System Implementation

YOLO or You Only Look Once, is one of the most widely used deep learning-based object detection algorithms out there. YOLOv5 over other variants is due to the fact that it's the most actively maintained Python port of YOLO. Other variants like YOLO v4 are written in C, which might not be as accessible to the typical deep learning practitioner as Python.

Working of YOLOv5:

- Set up the Code
- Download the Data
- Convert the Annotations into the YOLO v5 Format
 - YOLO v5 Annotation Format
 - Testing the annotations
 - Partition the Dataset
- Training Options
 - Data ConFigure File
 - Hyper-parameter ConFigure File
 - Custom Network Architecture
 - Train the Model
- Inference
 - Computing the mAP on test dataset

A. Introduction

Although it is seen as a routine task for the human brain to identify things in an image, doing so on a machine would be more difficult. A computer vision task known as "object detection" is locating and identifying things in images. Several methods have been developed in recent years to address this challenge. You Only Look Once (YOLO) is one of the most well-known real-time object identification algorithms to date. It was first proposed by Redmond et al. [16] and implemented in YOLOv5 by Ultralytics [17]. Our own model will be trained using transfer-learning approaches, and its performance will be assessed. It will then be used for inference, and it will even be converted to various file formats like ONNX and TensorRT.

Joseph Redmon, Santosh Divvala, Ross Girshick, and Ali Farhadi developed the cutting-edge, real-time object detection method known as YOLO in 2015. It was pre-trained using the COCO dataset. To process a whole

image, it only employs one neural network. The programme divides the image into areas, and for each region, it forecasts probability and bounding boxes. [24].

Yolo is well renowned for its speed and accuracy, and it has been utilised in numerous fields like self-driving automobiles, healthcare, and security monitoring. The Ultralytics team has been trying to improve this model since 2015, and numerous iterations have been released since then. This post will examine YOLOv5, the algorithm's fifth iteration.

1. High-level architecture for single-stage object detectors
2. YOLOv5 Architecture
3. Activation Function
4. Loss Function
5. Other improvements
6. YOLOv5 vs YOLOv4
7. Conclusion

High-level architecture for single-stage object detectors

There are two types of object detection models: two-stage object detectors and single-stage object detectors. Single-stage object detectors (like YOLO) architecture are composed of three components: **A backbone**, a **Neck**, and a **Head** to make dense predictions as shown in the figure below.

Model backbone: To extract rich feature representation for images, a pre-trained network is employed as the backbone. This aids in lowering the image's spatial resolution and raising its feature (channel) resolution.

Model Neck: Pyramids of feature data are extracted from the model neck. This makes it easier for the model to generalize to objects of various sizes and scales.

Model Head: The final stage procedures are carried out using the model head. It renders the finished product, which includes classes, objectness scores, and bounding boxes, by applying anchor boxes to feature maps.

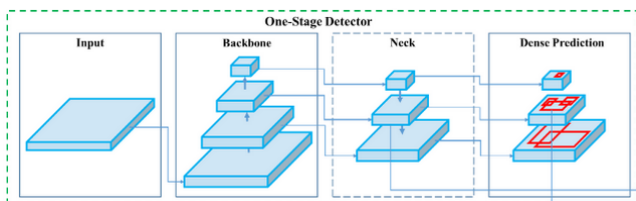

Figure 4: Single-Stage Detector Architecture

B. YOLOv5 Architecture

It is also good to mention that YOLOv5 was released in five different sizes:

- **n** for extra small (nano) size model.
- **s** for small-size models.
- **m** for medium size model.
- **l** for large size model
- **x** for extra large size model

Performance of YOLOv5 different sizes models.

There is no difference between the five models in terms of operations used except for the number of layers and parameters as shown in the table below. All the YOLOv5 models are composed of the same 3 components: **CSP-Darknet53** as a backbone, **SPP** and **PANet** in the model neck and the **head** used in YOLOv5.

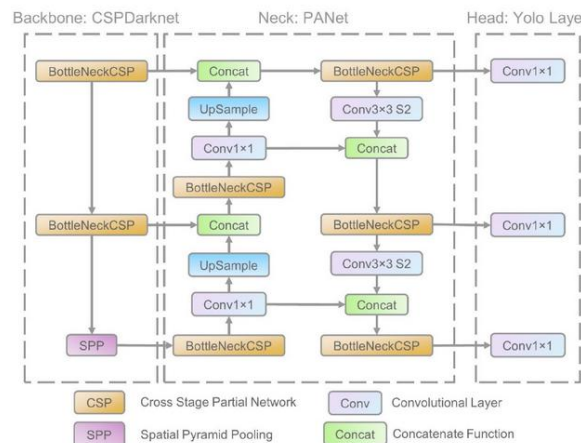

Figure 5: Network architecture for YOLO v5

C. Backbone of YOLOv5: CSP-Darknet53

YOLOv5 uses CSP-Darknet53 as its backbone. CSP-Darknet53 is just the convolutional network **Darknet53** used as the backbone for YOLOv3 to which the authors applied the **Cross Stage Partial (CSP)** network strategy.

1) Cross-Stage Partial Network

YOLO is a deep network; it uses residual and dense blocks in order to enable the flow of information to the deepest layers and to overcome the **vanishing gradient problem**. However one of the perks of using dense and residual blocks is the problem of **redundant gradients**. CSPNet helps tackle this problem by truncating the gradient flow. According to the authors of [3]:

CSP network preserves the advantage of DenseNet's feature reuse characteristics and helps reduce the excessive amount of redundant gradient information by truncating the gradient flow.

YOLOv5 employs the CSPNet strategy to partition the feature map of the base layer into two parts and then merges them through a cross-stage hierarchy as shown in the figure below.

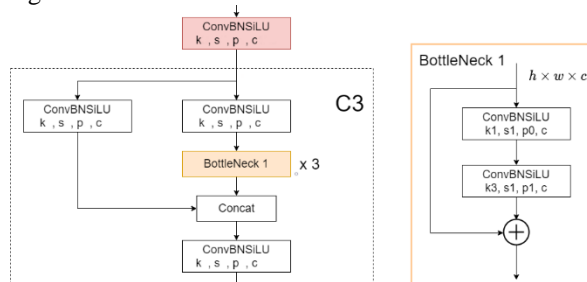

Figure 6: BottleNeckCSP module architecture

Applying this strategy comes with big advantages to YOLOv5, since it helps reducing the number of parameters and helps reducing an important amount of computation (less FLOPS) which lead to **increasing the inference speed** that is crucial parameter in real-time object detection models.

D. Neck of YOLOv5

YOLOv5 brought two major changes to the model neck. First a variant of **Spatial Pyramid Pooling (SPP)** has been used, and the **Path Aggregation Network (PANet)** has been modified by incorporating the **BottleNeckCSP** in its architecture.

Path Aggregation Network (PANet)

PANet is a feature pyramid network, it has been used in previous version of YOLO (YOLOv4) to improve information flow and to help in the proper localization of pixels in the task of mask prediction. In YOLOv5 this network has been modified by applying the CSPNet strategy to it as shown in the network's architecture figure.

Spatial Pyramid Pooling (SPP): SPP block performs an aggregation of the information that receives from the inputs and returns a fixed length output. Thus it has the advantage of significantly increasing the receptive field and segregating the most relevant context features without lowering the speed of the network. This block has been used in previous versions of YOLO (yolov3 and yolov4) to separate the most important features from the backbone, however in YOLOv5 (6.0/6.1) **SPPF** has been used, which is just another variant of the SPP block, to **improve the speed of the network**.

E. Head of the network

The same head as YOLOv3 and YOLOv4 is used by YOLOv5

It is made up of three convolution layers that forecast where the bounding boxes (x, y, height, and width), scores, and object classes will be. The equation to compute the target coordinates for the bounding boxes have changed from previous versions, the difference is shown in the figure bellow.

$$\begin{array}{ll} b_x = \sigma(t_x) + c_x & b_x = (2 \cdot \sigma(t_x) - 0.5) + c_x \\ b_y = \sigma(t_y) + c_y & b_y = (2 \cdot \sigma(t_y) - 0.5) + c_y \\ b_w = p_w \cdot e^{t_w} & b_w = p_w \cdot (2 \cdot \sigma(t_w))^2 \\ b_h = p_h \cdot e^{t_h} & b_h = p_h \cdot (2 \cdot \sigma(t_h))^2 \end{array}$$

Activation Function

Choosing an activation function is crucial for any deep learning model, for YOLOv5 the authors went with SiLU and Sigmoid activation function. **SiLU** stands for Sigmoid Linear Unit and it is also called the **swish** activation function. It has been used with the convolution operations in **the hidden layers**. While the **Sigmoid** activation

function has been used with the convolution operations in **the output layer**.

Loss Function

YOLOv5 returns three outputs: the **classes** of the detected objects, their **bounding boxes** and the **objectness scores**. Thus, it uses **BCE** (Binary Cross Entropy) to compute the **classes loss** and the **objectness loss**. While **CIoU** (Complete Intersection over Union) **loss** to compute the **location loss**. The formula for the final loss is given by the following equation

$$Loss = \lambda_1 L_{cls} + \lambda_2 L_{obj} + \lambda_3 L_{loc}$$

5. Future Work

As India is a developing country with both rich and poor people, this application has a broad future application. Some people have a lot of resources, while others can't even afford a basic way of life. If this donation business is put online, people will be able to donate their extra items without feeling awkward, and those who will benefit will be able to do so. These items are available to those who require them. Furthermore, this application will be extremely useful in the event of a natural disaster. Calamity such as an epidemic break where people would be able to donate food and clothing to those in need of Indian citizens. Hundreds of thousands of dollars in food is wasted during celebrations such as a wedding or a party because no one wants to spend their time looking for people to donate their food, so our application will make their job easier because they don't have to do anything but register with this application and someone will pick up the items. This application can further be enhanced by image detection at the donor's end with the perspective of do's and don'ts while donating an item. Can further be enhanced by adding a GPS feature and face recognition for security. This application can be enhanced by furthermore by adding a feature of quality detection of an Item being donated. Where the machine can detect whether the donated item is of good quality.

6. Conclusion

In this project, we used the YOLOv5 model for clothes, toys, books, and other items for image classification. This classification requires multiple stages, such as preprocessing and image segmentation, followed by feature extraction and classification. proper selection of the classification technique is the core point for best results. The system will be able to differentiate between shirts, t-shirts, pants & shoe images donated to NGOs by different donors. It can be said that if this application reaches to all the people of India than it is going to bring joy in life of many people as some will feel happy by donating food, clothes and books and the people who will receive these items will also feel happy. This application can play a major role to help India become more developed in coming future by making all the citizen of India happy and prosperous. This application will help those people who suffer from malnutrition and salvation, people who can't

get books to educate themselves, and people who have to wear same torn old clothes in their daily life. This is an initiative taken by us to help the citizen of our country by making their life easier.

References

- [1] Hanyang WU and Xianchen Zhu, "Developing a Reliable Service System of Charity Donation during the COVID19 Outbreak", IEEE Access Vol 8, 2020 DOI: 10.1109/ACCESS.2020.3017654
- [2] Tong Li; Donghui Hu; Meng Li; Yifan Li; Shuli Zheng, "A Blockchain-based Material Donation Platform", 2022 International Conference on Blockchain Technology and Information Security (ICBCTIS), DOI: 10.1109/ICBCTIS55569.2022.00061
- [3] Aditya Pathak; Shriram Rajaraman; Sharmila Sengupta; Atharva Pandit; Rushi Yawalkar "Ek Ka Josh", 2018 International Conference on Smart Systems and Inventive Technology (ICSSIT), DOI: 10.1109/ICSSIT.2018.8748628
- [4] Naman talati ; Omkar surve; Jenil shah and Sher keyal, "Food donation portal" proposed in by IJSRD-Vol.4, Issue 11, 2017| ISSN
- [5] H Saleh ; Sergey Avdoshin; Azmat Dzhonov, "Platform for Tracking Donations of Charitable Foundations Based on Blockchain Technology", 2019 Actual Problems of Systems and Software Engineering (APSSE) DOI: 10.1109/APSSE47353.2019.00031
- [6] Billy Sentosa Wijaya; Immanuel Yohansen; Jeremy; Tanty Oktavia, "Fridge Inventory Management to reduce Household Food Wastage" 2020 International Conference on Information Management and Technology (ICIMTech), DOI: 10.1109/ICIMTech50083.2020.9211142
- [7] Shubham Singh Rana; satvik Maheswari; Shiv Kumar; Ms. Jyoti Thakur "Get a Bite", Volume XII, Issue IV, 2020 ISSN No : 1006-7930
- [8] Shubham Belekar1, Rahul Rajput2, Karan Gharat3, Prof. Pallavi Raut "Mobile Application for donation", VIVA-Tech International Journal for Research and Innovation Volume 1, Issue 4 (2021) ISSN: 2581-7280
- [9] Sandro Rodriguez Garzon; Mustafa Elbehery; Bersant Deva; Axel Küpper, "Reliable Geofencing: Assisted Configuration of Proactive Location-based Services", 2016 IEEE International Conference on Mobile Services (MS), DOI: 10.1109/MobServ.2016.42
- [10] K. Jayalakshmi; S.Pavithra C.; Aarthi, "Waste to Wealth- A Novel Approach for Food Waste Management", 2017 International Conference on Electrical, Instrumentation and Communication Engineering (ICEICE2017)
- [11] J Manikandan; Mr N Kumar; "Food Wastage Reduction through Donation", Volume: 07 Issue: 03 | Mar 2020 International Research Journal of Engineering and Technology (IRJET) e-ISSN: 2395-0056
- [12] Junho Jeong; Donghyo Kim; Yangsun Lee; Jin-Woo Jung; Yunsik Son "Private Donation System Based on Blockchain for Transparency and Privacy", 2020 International Conference on Electronics, Information, and Communication (ICEIC), DOI: 10.1109/ICEIC49074.2020.9051328
- [13] Wooyoung Lee; Dukjin Kim; Byeong Ryun Jeon "A Study on Blockchain Application in Donation Platform" 2021 21st ACIS International Winter Conference on Software Engineering, Artificial Intelligence, Networking and Parallel/Distributed Computing (SNPD-Winter), DOI: 10.1109/SNPDWinter52325.2021.00075
- [14] N Gayathri; A R Divagaran; C D Akhilesh; V M Aswiin; N Charan, "IoT Based Smart Waste Management System" 2021 7th International Conference on Advanced Computing and Communication Systems (ICACCS), DOI: 10.1109/ICACCS51430.2021.9441819
- [15] <https://blog.paperspace.com/train-yolov5-custom-data/>
- [16] <https://www.researchgate.net/>
- [17] <https://github.com/ultralytics/yolov5>
- [18] https://en.wikipedia.org/wiki/Unified_Modeling_Language
- [19] <https://www.tutorialspoint.com/sqlite/index.htm>
- [20] <https://reactjs.org/>
- [21] <https://www.w3schools.com/js/>
- [22] <https://www.python.org/>
- [23] <https://flask.palletsprojects.com/en/2.2.x/>