

IoT Based Smart Sensor for Humidity and Temperature Measurement in HVAC Systems

Chirayu Pranav Darji

Department of Electronics and Communication Engineering, Faculty of Technology, Dharmsinh Desai University, Nadiad, Gujarat, India
chirayudarji2000[at]gmail.com

Abstract: The initials HVAC stand for Heating, Ventilation and Air Conditioning. They describe the functions of an HVAC system. This mechanical system's design is primarily an attempt to take control of the environmental conditions inside the space of work. It achieves this by controlling the temperature of a room through heating and cooling. It also controls the humidity level in that environment by controlling the movement and distribution of air inside the room. For determining the temperature and humidity, costly sensors are required. Hence here I am proposing a SMART HUMIDITY AND TEMPERATURE SENSOR which is economical and supports automatic reading of the sensors, and sends the reading to a secured server and automatically controls the temperature and humidity of the system.

Keywords: HVAC System, Humidity control, Temperature control, Arduino

1. Introduction

The Smart Sensor is an IOT based module within a HVAC system. Using Internet of Things (IOT), we can control any electronic equipment in the sensor. We read the data from the sensor and analyze it graphically. Here, we read the temperature and humidity data from DHT11 sensor and upload it to a ThingSpeak cloud using Arduino Uno and ESP8266-01 module. Arduino Uno is a MCU, it fetches the data of humidity and temperature from DHT11 sensor and processes it and give it to a ESP8266 Module, which is a WiFi module. It transfers the data to IOT cloud every minute. The user can view the temperature and humidity level on their respective channel.

2. Hardware Requirements

- **Arduino UNO-** Main Controlling Unit, processes the temperature and humidity values and send it to the WiFi-Module.
- **WiFi-Module (ESP8266-01)** – Uploads the data of humidity and temperature to the server.
- **DHT11-** The DHT11 is a basic, ultra low-cost digital temperature and humidity sensor.
- **AMS1117-3.3V** – It is a Voltage regulator circuit.
- **9V battery/ DC Power Supply**

3. Software Requirements

- **Arduino IDE**
- **Thingspeak** – IoT server

4. Block Diagram

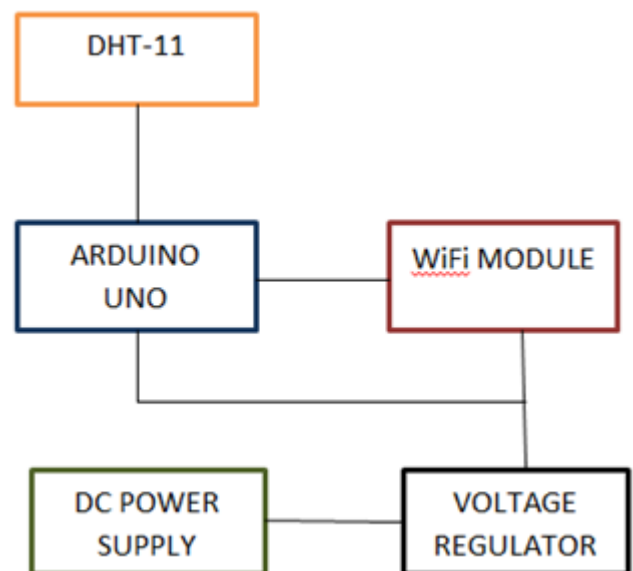

5. Working of the Circuit

DHT-11 sends temperature and humidity value to the arduino Uno. Arduino processes the values of humidity and temperature and sends it to ESP-8266. ASM1117 regulates the input voltage from the battery/power supply at 3.3 v. The WiFi Module sends the values of humidity and temperature to Thingspeak cloud server, where we get to see a graphical representation of the values.

6. Graphical Representation of Data on Server

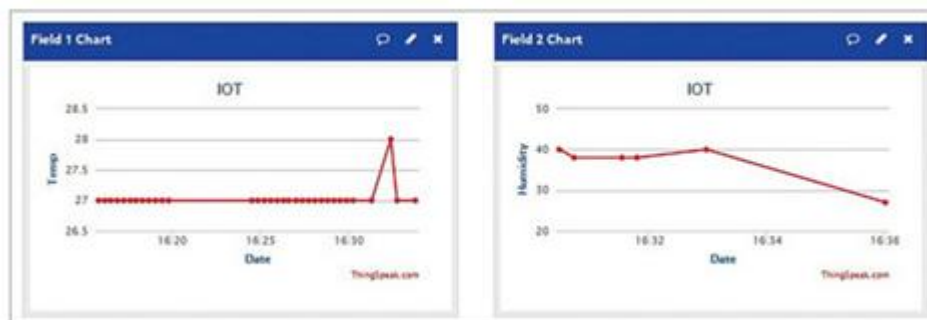

7. Conclusion

The complete model of smart humidity and temperature sensor was successfully built and tested. The model worked at normal room temperature and humidity. Automatic sensing and control of the temperature and humidity was achieved for a HVAC system. The expensive machinery used previously would be replaced by an efficient and less costly smart sensor. Also, the data is now available on the server for analysis.

References

- [1] <https://www.arduino.cc/>: website of Arduino
- [2] <https://www.servicechampions.net/blog/what-is-an-hvac-system/>
- [3] <https://thingspeak.com/>: website of Thingspeak

Author Profile



Chirayu Pranav Darji is currently a student of B.Tech. degree in Electronics and Communication Engineering from Faculty of Technology, Dharmsinh Desai University, and will graduate in the year 2022.